

## Millimeter Wave Noise Sources -Series THZNS-XXFB

### General Features

- Full band coverage from 110-170 GHz
- Compatible with standard noise figure meters\*
- Use with Noise Test Set Downconverters\*\*
- Integrated Isolator
- High ENR with flat response
- Provided with calibration data
- Automatic noise measurements in mm-wave bands

### Specifications

Model	Frequency Range (GHz)	Noise Source ENR (dB) typical	VSWR	Waveguide Interface
THZNS-19FB	40 - 60	12 +/- 2.5	1.5: 1 max	WR 19, UG387/U-M
THZNS-15FB	50 - 75	12 +/- 2.5	1.5: 1 max	WR 15, UG387/U-M
THZNS-12FB	75 - 110	12 +/- 2.5	1.5: 1 max	WR 12, UG387/U-M
THZNS-10FB	90 - 140	12 +/- 2.5	1.5: 1 max	WR 10, UG387/U-M
THZNS-08FB	140 - 220	12 +/- 2.5	1.5: 1 max	WR 08, UG387/U-M
THZNS-06FB	110 - 170	12 +/- 2.5	1.5: 1 max	WR 06, UG387/U-M

### Notes

- 1.\*Keysight N8975A/B and others
2. Trigger voltage; TTL 1 KHz max
3. DC power; +18 to 28 V < 100 mA typical
4. Stability 0.01 dB/deg C
5. Noise Source is supplied with isolator and calibration data
6. Operating Range 0-30 deg C. Specifications apply at 25 deg C
7. \*\*Details on request



Figure 1. 110-170 GHz Noise Source with Isolator

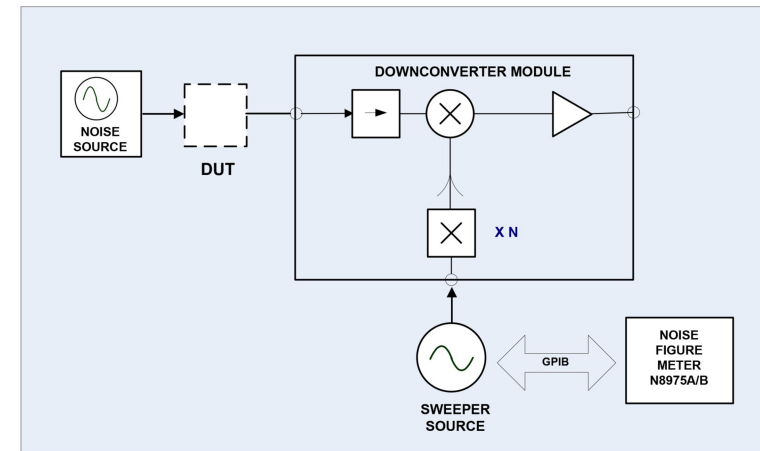

\*\*Figure 2. Noise Test Set Measurement System - Example